

SERVICE MANUAL

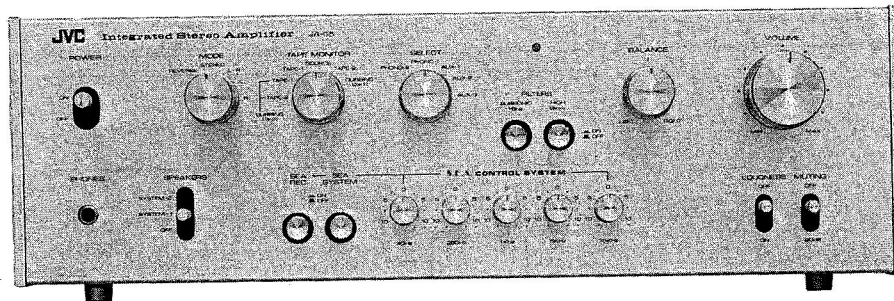

MODEL JA-S5

SOLID STATE STEREO INTEGRATED AMPLIFIER

DIMENSIONS : Height 5-3/8", Width 16-5/8", Depth 12-1/2" WEIGHT : 22 lbs.

SPECIFICATIONS

Type	: Solid State Stereo Integrated Amplifier	Load Impedance	: 4Ω~16Ω
Transistors	: 28	Damping Factor	: 30 at 8Ω (20Hz~20kHz)
Diodes	: 8	PRE-AMPLIFIER SECTION	
Input	: PHONO-1, PHONO-2, AUX-1, AUX-2, AUX-3, TAPE PLAY-1, TAPE PLAY-2, MAIN IN, 4 CHANNEL REAR IN.	Input Sensitivity/ Impedance	: Phono 1 & 2 2.5mV/47kΩ Aux 1, 2 & 3 150mV/60kΩ Tape Mon. 150mV/60kΩ
Output	: TAPE REC-1, TAPE REC-2, PRE OUTX 2, 4 CHANNEL REAR OUT, SPEAKERS SYSTEM-1, SPEAKERS SYSTEM-2, HEADPHONES	Signal to Noise Ratio	: Phono 88dB (IHF), 63dB (RMS) Aux 102dB (IHF), 83dB (RMS)
DIN Socket	: TAPE-1	Recording Output Level	: 150mV
Front Panel Controls	: POWER SWITCH, TAPE MONITOR, SELECT, BALANCE, VOLUME, SEA CONTROL SYSTEM, SEA ON OFF, SEA REC., MUTING, LOUDNESS, SPEAKERS SELECT, SUBSONIC FILTER, HIGH FILTER, MODE	Phono Equalizer Deviation	: ±0.5dB from RIAA
POWER AMPLIFIER SECTION		Phono Over Load	: 250mV (RMS), 700mV (p-p) at 1kHz
RMS Power	: 35W per channel at 8Ω	Frequency Response	: 10Hz~60kHz ±0.5dB
Both channels driven	36W per channel at 4Ω	SEA Center Frequency	: 40, 250, 1000, 5000, 15000Hz
20~20kHz power bandwidth		SEA Control Range	: ±12dB
RMS Power	: 80W (40W X 2) at 8Ω	Loudness Control	: +11dB at 50Hz
Both channels driven	80W (40W X 2) at 4Ω	(at -30dB Volume Control):	+4dB at 10kHz
at 1kHz		Subsonic Filter	: 6dB/oct at 18Hz
Total Dynamic Power	: 110W (55W X 2) at 8Ω	High Filter	: -6dB/oct at 9kHz
(IHF)	: 140W (70W X 2) at 4Ω	Muting	: -20dB
IHF Power Bandwidth	: 10Hz~40kHz	Crosstalk	: 50dB at 1kHz
Total Harmonic Distortion:	0.25% at rated output (0.05% at half rated output)	Maximum Output	: 3V at 1kHz
Intermodulation Distortion:	0.4% at rated output (0.1% at half rated output)	Total Harmonic Distortion	: 0.1% at rated output voltage
Frequency Response	: 5Hz~200kHz -3dB at 1W output	POWER CONSUMPTION	: Refer to Back Cover
Signal to Noise Ratio	: 96dB	POWER SOURCE	:
Input Sensitivity/ Impedance	: 1V/30kΩ	DIMENSIONS	: 5-3/8"H X 16-5/8"W X 12-1/2"D
		WEIGHT	: 22 lbs.

BLOCK DIAGRAM

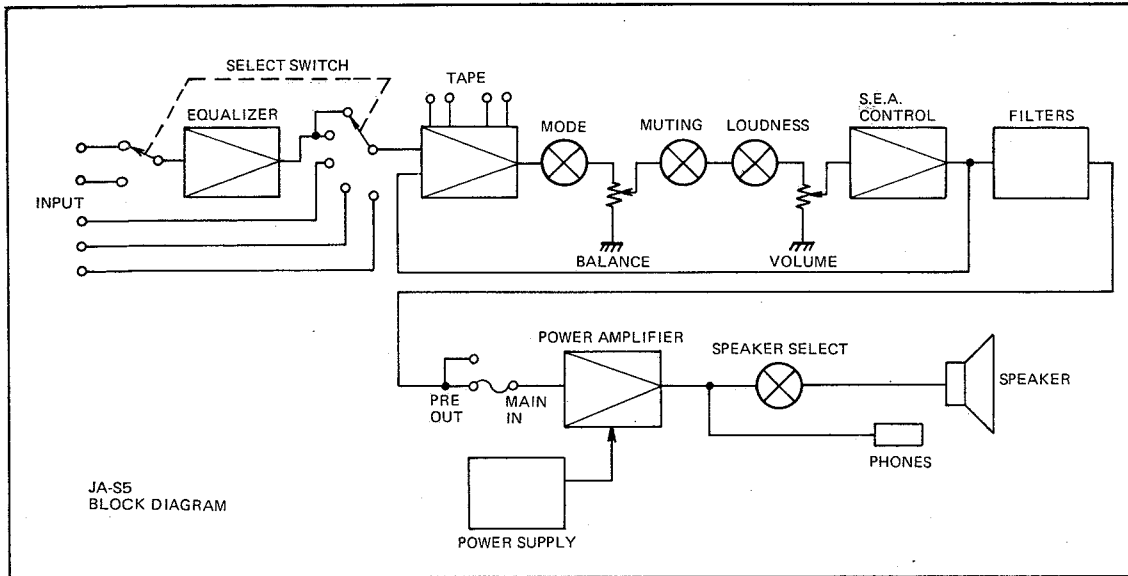

Fig. 1

LEVEL DIAGRAM

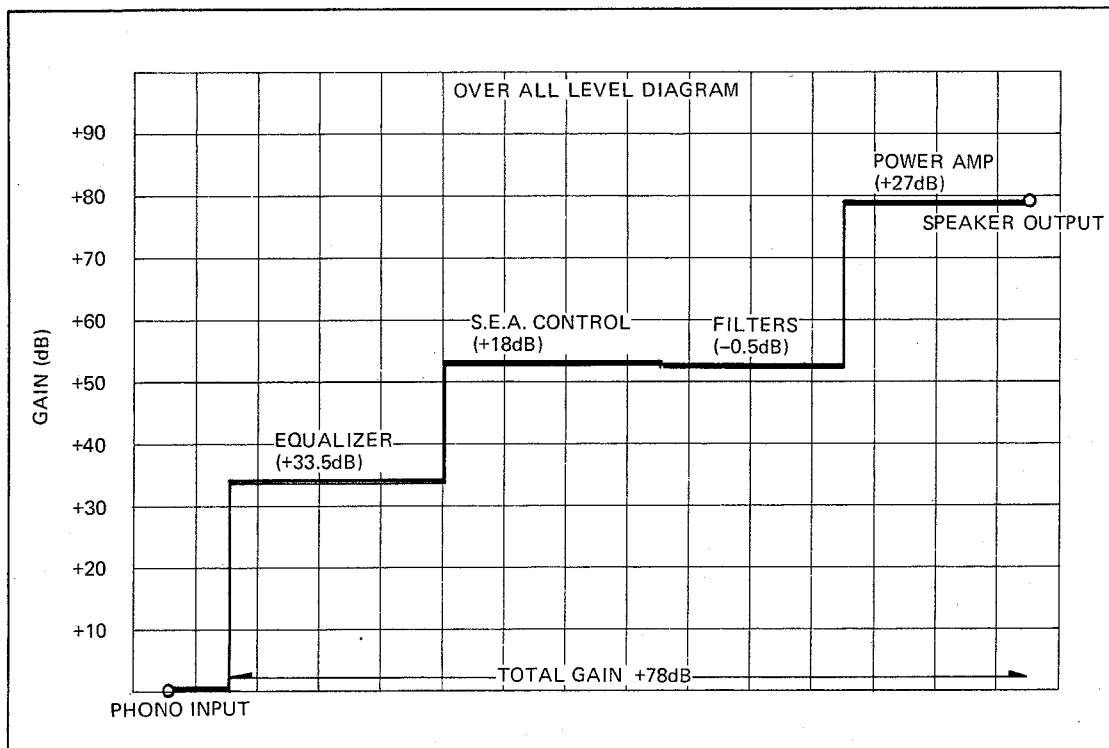

Fig. 2

FEATURES

① All-Stage Direct-Coupled Pure Complementary OCL Power Amplifier

The power amplifier in the JVC JA-S5 is the type found usually only in more expensive hi-fi instruments. Its all-stage direct-coupled pure complementary circuitry is the latest in state-of-the-art design and provides very low distortion and high stability with an RMS output of 40W per channel (at 1kHz, both channels driven at 8 ohms). This first-class operation is possible thanks to the application of high negative feedback in vital areas, and means always-reliable performance even when musical signals of the most extreme complexity and subtlety are present.

② Advanced Phono Equalizer

The phono equalizer in the JA-S5 keeps deviation from the standard RIAA equalizer curve to no more than ± 0.5 dB, a figure that compares favorably with any top-grade amplifier. Since it accepts phono input signals of up to 250 mV (RMS), full dynamic range is assured to faithfully reproduce a wide range of sound intensities — from the faintest pianissimo to an ear-splitting fortissimo. The JA-S5 reproduces all the sounds on the record with proper balance and perfect clarity.

③ Safeguarded Phono Equalizer Eliminates High-Frequency Attenuation

The JA-S5 features a simple but revolutionary design innovation: by placing the phono equalizer section in the rear of the chassis, and connecting the rear-panel PHONO terminals directly to the equalizer by means of sockets, the need for lengthy inter-connections of shielded wire is eliminated. The front-panel control for source selection is connected to the equalizer by a long shaft (see illustration). The danger of having high-frequency signals attenuated or otherwise damaged by electrical resonance is thus greatly reduced. The use of shielded wire is reduced throughout the JA-S5 to about one-third of what ordinary amplifiers usually use, thanks to the application of the same direct-coupling method to tape monitor facilities and the development of a highly functional chassis. This design extends the transparency of high frequencies and also reduces manufacturing costs.

④ JVC's Exclusive S.E.A. Tone-Zone System and S.E.A. Recording

The popular success of the S.E.A. (Sound Effect Amplifier) System developed by JVC (U.S. Patent No. 3566294) has persuaded countless numbers of customers to buy JVC high fidelity products over all the competition. Each of the five tone-zone controls in the S.E.A. in the new JA-S5 has a plus/minus adjustment range of 12 dB — a vast improvement over conventional bass/treble tone controls. A further bonus is that this S.E.A. System can be used for recording to either (or both) of the two tape decks which can be connected to the JA-S5. The S.E.A. REC switch on the front panel is provided for this purpose.

⑤ Jumbo Power Transformer and Capacitors

The power performance of the JA-S5 is enhanced by its heavy (2.9 kg), oversized power transformer and two jumbo capacitors (6,800 μ F each). A re-allocation of the parts and production costs in this new JA Series has allowed JVC to provide this extra assurance that stability is maintained against any pulsive, transient or continuous power abnormality.

⑥ Self-Restoring Triple Power Protection Circuit

The dual power supply requirements of the OCL power amplifier in the JA-S5 has many advantages, as mentioned above. OCL amplifiers, however, need special power protection to prevent unexpected power surges and other abnormalities from causing damage to the power transistors or the connected speaker systems. The patented protection circuit (U.S. Pat No. 3691427) in the JA-S5 deals with such problems in these three ways:

- 1) A four-second delay is provided between the time power is switched on and the time that any signal reaches the speaker circuit. (It also provides a 0.1-second delay from power-off to circuit disconnection.) This does away with the "thump-pop-crackle" sounds from speakers and protects the delicate speaker units as well.
- 2) The circuit detects abnormally low or high voltage at the speaker terminals and acts instantly to break connections when necessary.
- 3) The power transistors in the amplifier are protected from damage due to accidental short-circuits in speaker leads or when an excessively low speaker impedance is applied.

The power protection circuit in the JA-S5 restores itself automatically once the abnormality is corrected, thus eliminating need to replace fuses.

⑦ 4-Gang Volume Control for 4-Channel Adaptability

As an extra convenience, the JA-S5 is designed for quick and easy incorporation in an advanced 4-channel system. The volume control is provided with a 4-gang potentiometer so that it can be used as a 4-channel master control when inter-connected with another stereo amplifier. Input and output terminals are provided on the rear panel of the JA-S5 for such use. Loudness and muting controls are also designed to work in the 4-channel mode.

⑧ Dual Tape Monitor Circuits and Tape-to-Tape Dubbing

The 6-position Tape Monitor switch on the front panel of the JA-S5 is easy to operate and provides a wide range of uses. Up to two separate stereo tape decks can be connected through rear-panel terminals and can be separately monitored for playback. Further, any source signal can be recorded into either deck individually, or into both simultaneously. And for extra convenience, the Tape Monitor switch provides two positions for deck-to-deck tape dubbing: Tape 1 to 2 or Tape 2 to 1. (When dubbing from Deck 1 to 2, either deck may be monitored, providing it is the three-head type.) The S.E.A. REC facility mentioned above, and the fact that any of the three separate stereo AUX circuits can be used for third-deck playback, extend the tape versatility of the JA-S5.

⑨ Twin Pre-Out Terminals

Two separate sets of stereo terminals are provided on the rear panel of the JA-S5 for deriving output signals from the pre-amplifier section. These PRE-OUT taps mean that an additional power amplifier, a separate VU monitor unit or other such instruments can be employed.

HOW TO CHECK THE CENTER VOLTAGE AND THE IDLING CURRENT OF POWER AMPLIFIER

NOTE: Allow the set to warm up at least for 10 minutes before you begin the following procedure.

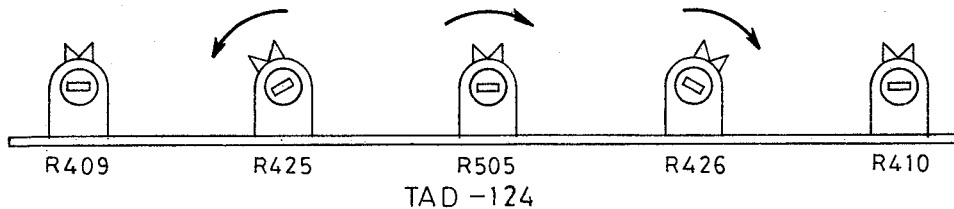

Fig. 3

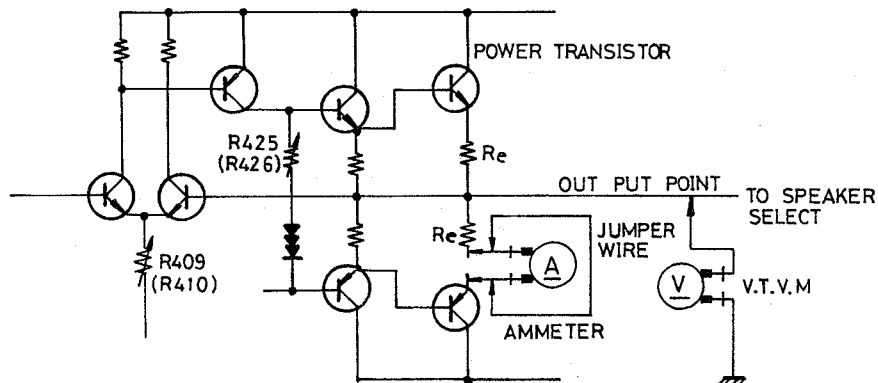

Fig. 4

Connect of a measurement instrument as shown Fig. 4. This circuit is the standard one of main amplifier.

- Turn VOLUME control to minimum

- (1) Connect the probe of VTVM (D.C.) to a positive pole of output point. And connect the ground lead of VTVM (D.C.) to a chassis.
- (2) Insert an ammeter and a jumper wire together shown Fig. 4.

NOTE : After the power switch has been turned on and jumper wire has been take off, adjust the idling current in order to protect the ammeter against being damaged by surge current.

- Turn POWER SWITCH on

- (1) VTVM (D.C.) ought to show zero V. If VTVM (D.C.) is not zero V adjust R409(R410) to VTVM (D.C.) reading of zero V.
- (2) An ammeter ought to show 10mA~20mA. If an ammeter reading of volume are not 10mA~20mA, adjust R425(R426) to an ammeter reading of 10mA~20mA.

NOTE : The adjustment of the center voltage of power amplifier should be performed before measuring the idling current.

NOTE : The adjustment of the center voltage of power amplifier should be performed before measuring the idling current.

PACKING ILLUSTRATION

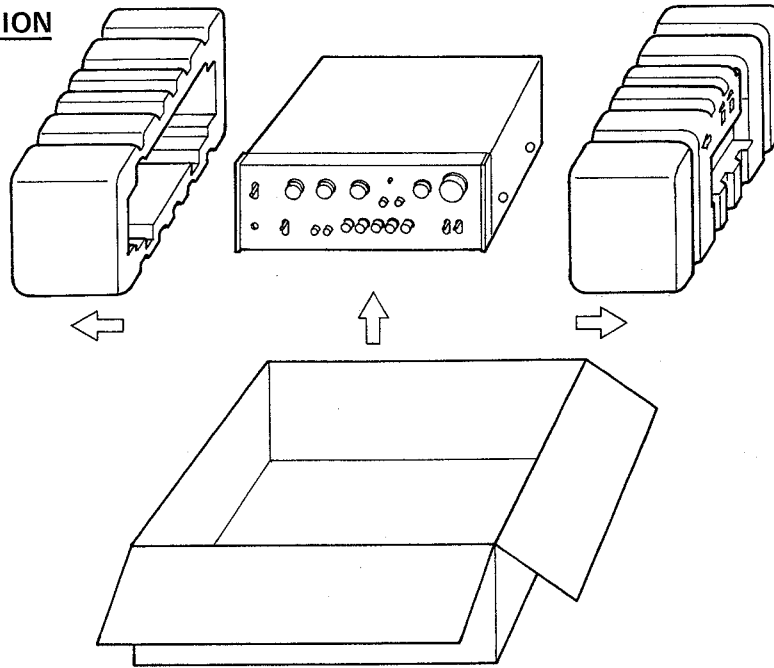

Fig. 5

Parts No.	Parts Name	Description
JAS5-PK	Packing Case	
JAS5-NZ	Fillers	
E32332-004	Envelope	for Set

ACCESSORIES

E30580-428A	INSTRUCTION BOOK
E64207-002	ENVELOPE
E64103-001	POLISHING CLOTH
E30539-417A	SCHEMATIC DIAGRAM
QMF61U1-3R0	FUSE (125V 3A) (Refer to back cover about the parts number)
E64208-001	ENVELOPE
BT-20002C	WARRANTY CARD

USED TRANSISTORS & DIODE

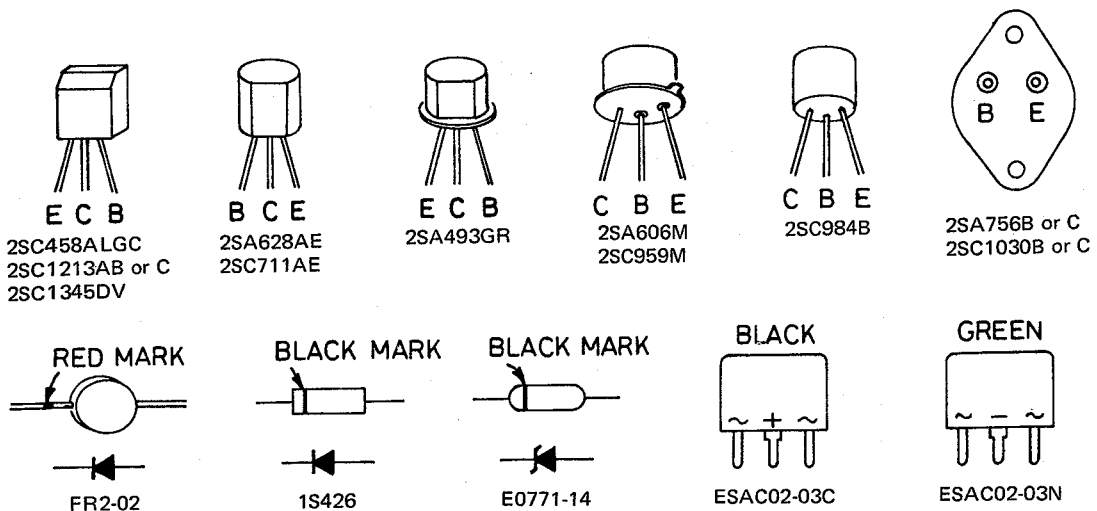

Fig. 6

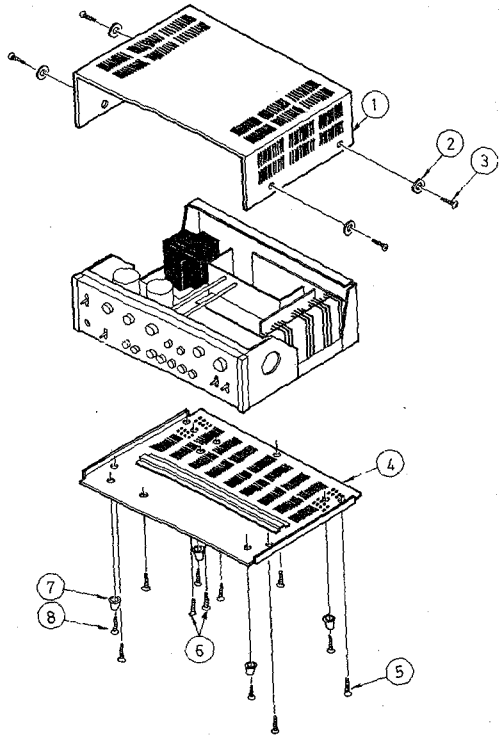

Fig. 7

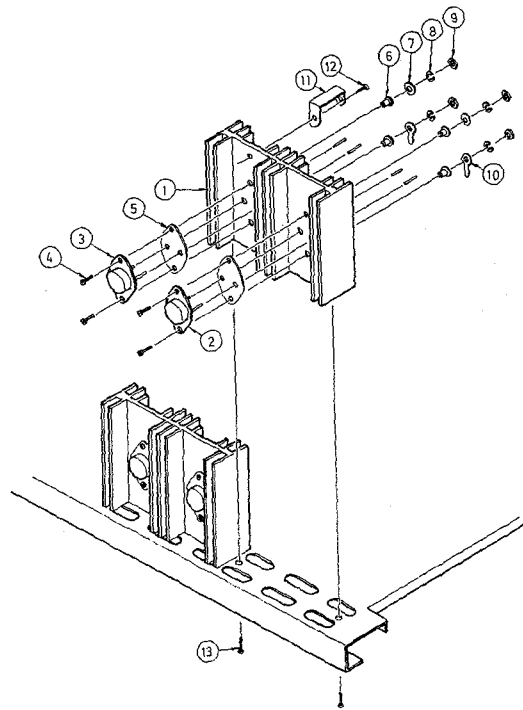

Fig. 8

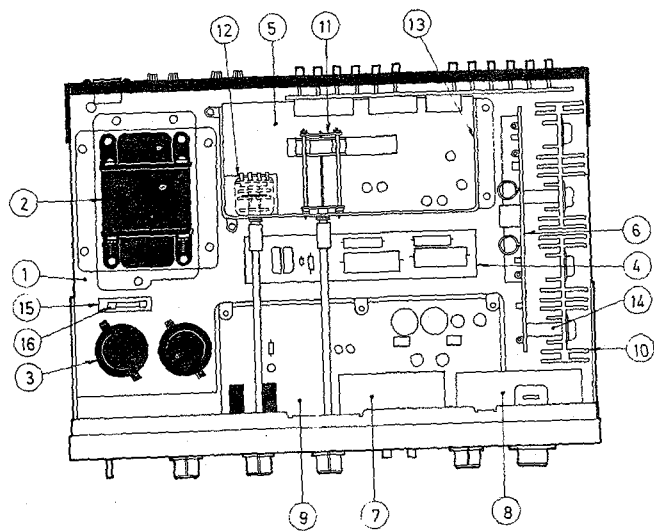

Fig. 9

THE LIST OF FRONT MECHANICAL PARTS FOR REPLECEMENT

Dwg. No.	Parts No.	Parts Name	Description
1	E1739-002	Front Panel Ass'y	
2	SBSB3008C	Tapping Screw	
3	E48551-001	Knob	For Volume
4	E48552-001	"	For Balance Mode
5	E48553-001	Select Knob	
6	E47960-001	Knob	For S.E.A.
7	E47254-005	Push Switch Knob	
8	E1665-005	Front Bracket	
9	QSU1221-001	Lever Switch	For Power SW
10	SSSB3008N	Tapping Screw	
11	E45979-012	Spacer	
12	QMS6301-001	Head Phone Jack Ass'y	
13	QSL4335-004	Lever Switch	For Speaker Select.
14	SSSP3006NS	Ass'y Screw	
15	E45979-008	Spacer	
16	QSR0017-001	Mode Switch	
17	QML1310-043	Lug Terminal	
18	SBSB3008N	Tapping Screw	
19	E46029-001	Rubber Bushing	
20	QLP3104-101	Mini Lamp.	
21	E46880-001	Bushing	
22	Q03091-141	Washer	
23	E5357-2	Nut	
24	E47060-004	Shaft	
25	REE4000	E. Ring	
26	"	"	
27	E47061-003	Connector	
28	E47610-002	Push Switch Bracket	
29	TAC-293	Filter C. B. Ass'y	
30	SSSP3006NS	Ass'y Screw	
31	"	"	
32	TAC-294	Volume C. B. Ass'y	
33	QSL4235-032	Lever Switch	
34	SSSP3006NS	Ass'y Screw	
35	E45979-007	Spacer	
36	TAC-229G	S.E.A. C. B. Ass'y	
37	E33085-001	S.E.A. C. B. Bracket	
38	E47611-001	Push Switch Bracket	
39	SBSB3006N	Tapping Screw	
40	SBSB3006N	"	
41	E47804-001	Bracket	
42	SBSB3008N	Tapping Screw	
43	SBSB3006N	"	
44	SBSB3008N	"	

EXPLODED VIEW OF MECHANICAL PARTS (FRONT PANEL)

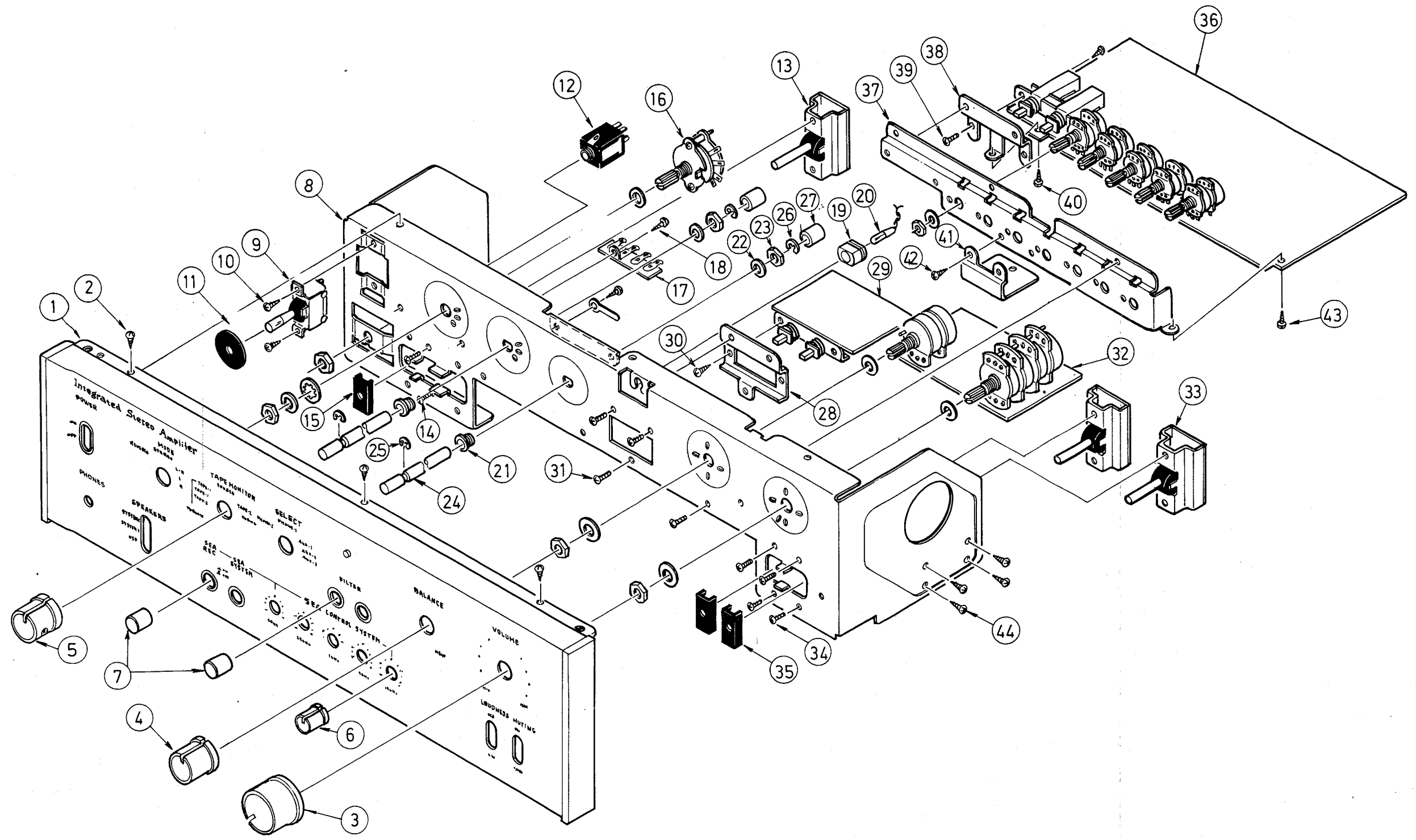

Fig. 10

EXPLODED VIEW OF MECHANICAL PARTS (REAR PANEL)

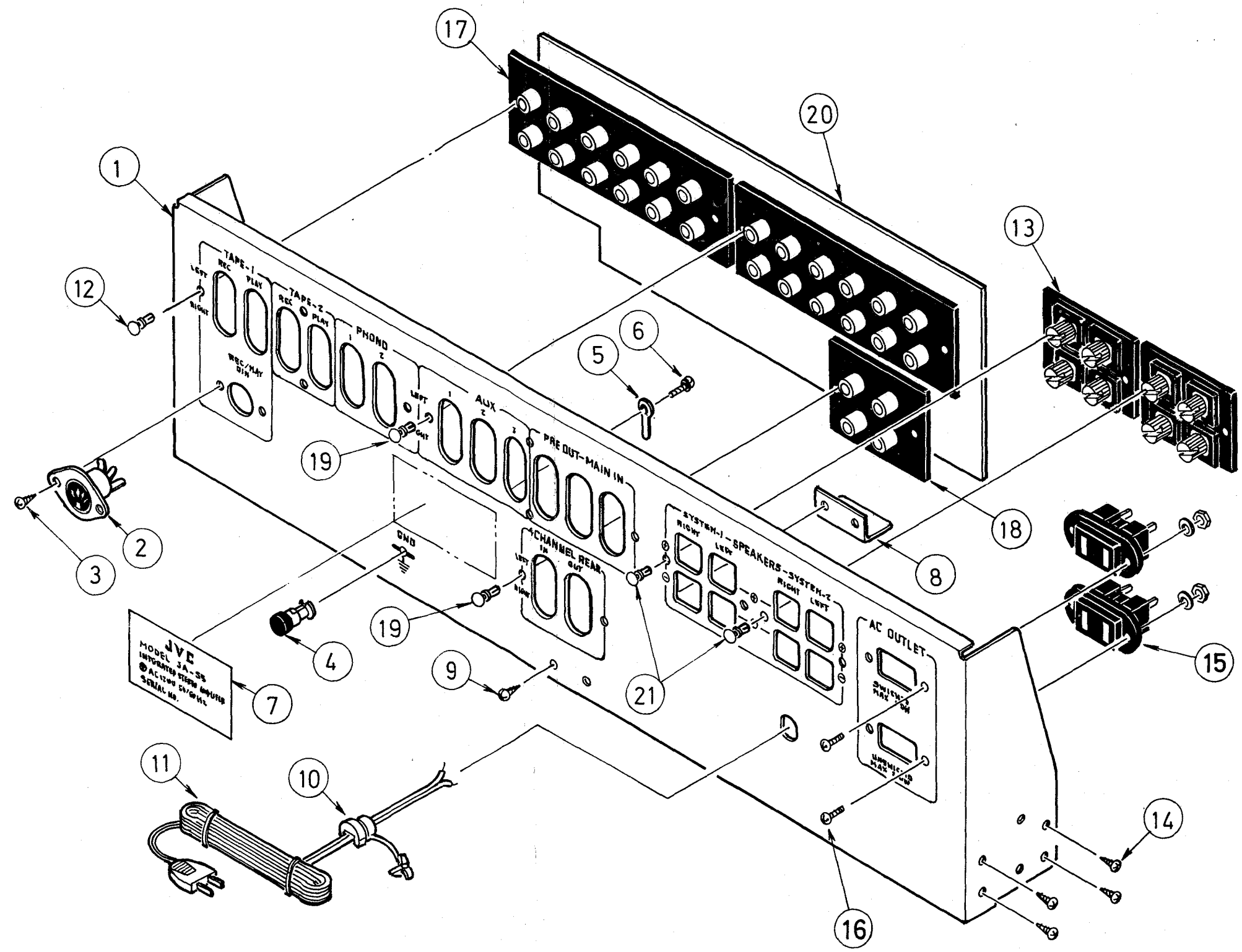

Fig. 11

THE LIST OF REAR PANEL PARTS FOR REPLACEMENT

Dwg. No.	Parts No.	Parts Name	Description
1	E21114-004	Rear Panel	(Earth)
2	QMC0589-001	Din Socket Ass'y	
3	SBSB3008N	Tapping Screw	
4	E04069-001S	Push Terminal	
5	52868-3	Lug Terminal	
6	LPSP3005NS	Ass'y Screw	
7	E47330-096	Rating Plate	
8	E44366-001	Bracket	
9	SBSB3008M	Tapping Screw	
10	E31704-001	Cord Stopper	
11	QMP1200-244	Power Cord	
12	E48729-001	Plastic Rivet	
13	E03572-001	Terminal Ass'y	
14	SBSB3008M	Tapping Screw	
15	QMC0234-001	AC Socket	
16	SPKP3010S	Screw	
17	E03043-122	Pin Jack Ass'y	
18	E03043-42	"	
19	E48729-001	Plastic Rivet	
20	TAC-295	Pin Jack C. B.	
21	E48729-001	Plastic Rivet	

TAP-199B POWER SUPPLY CIRCUIT BOARD ASS'Y (BOTTOM VIEW)

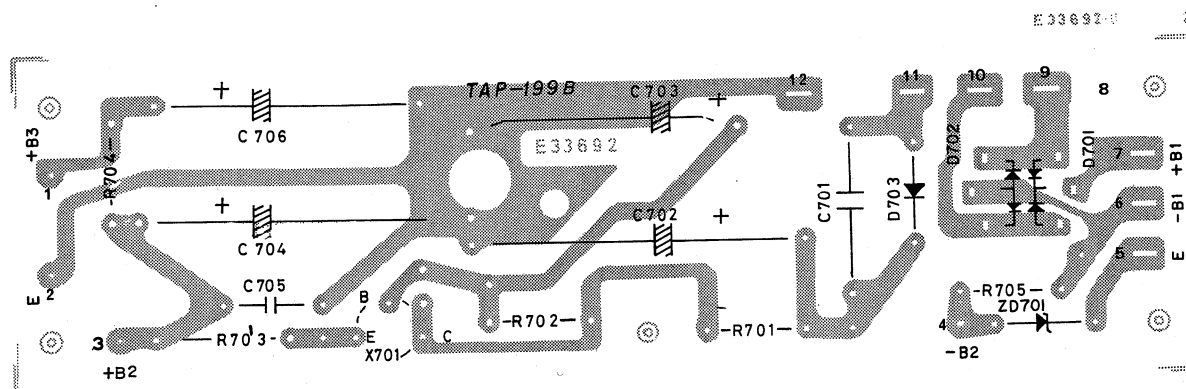

Fig. 12

TAC-293 FILTER CIRCUIT BOARD ASS'Y (BOTTOM VIEW)

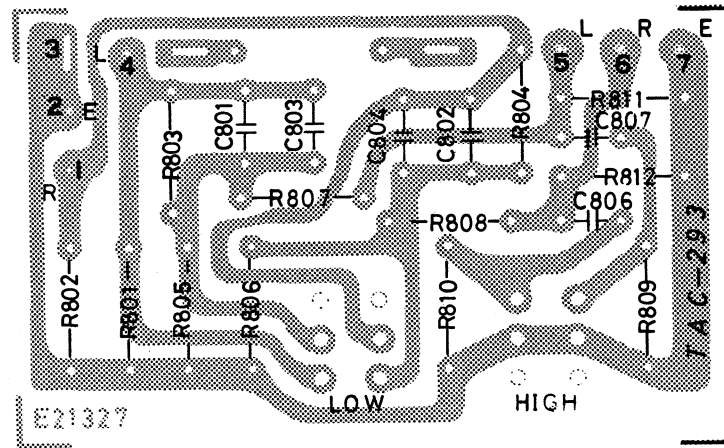

Fig. 13

TAC-294 VOLUME CIRCUIT BOARD ASS'Y (BOTTOM VIEW)

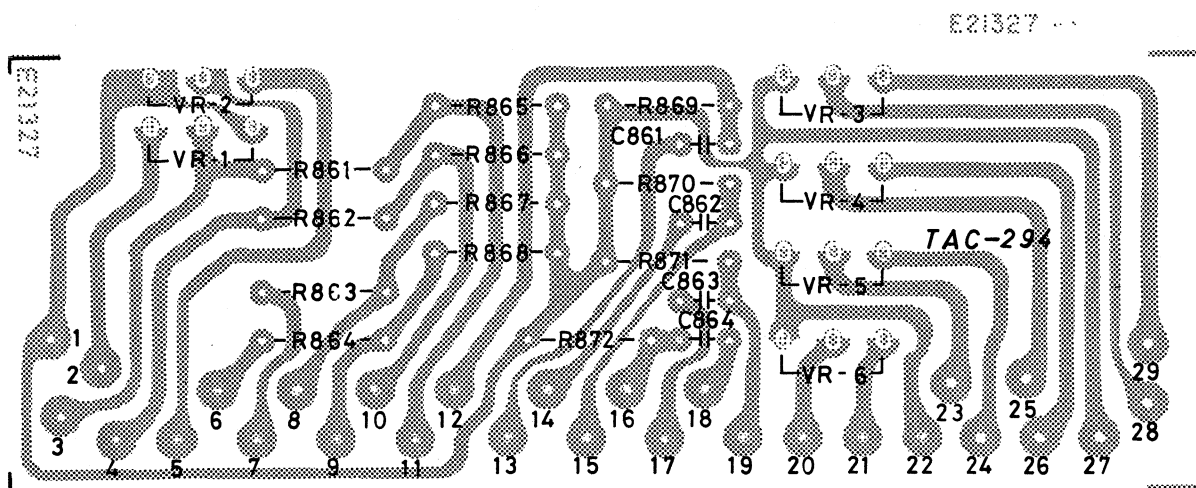

Fig. 14

TAE-74 EQUALIZER CIRCUIT BOARD ASS'Y (BOTTOM VIEW)

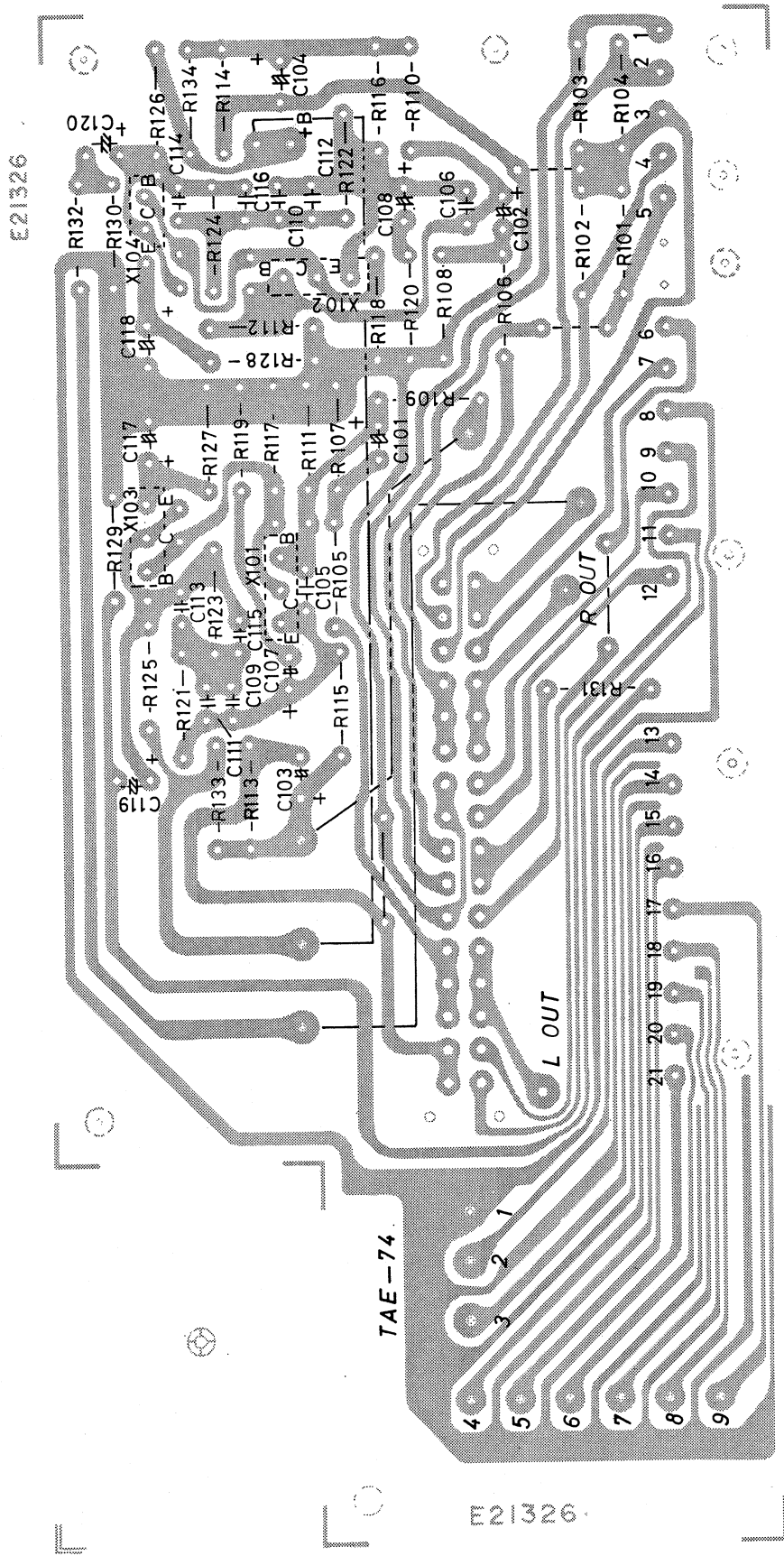

Fig. 15

TAD-124B DRIVE AMP. AND PROTECTION CIRCUIT BOARD ASS'Y (BOTTOM VIEW)

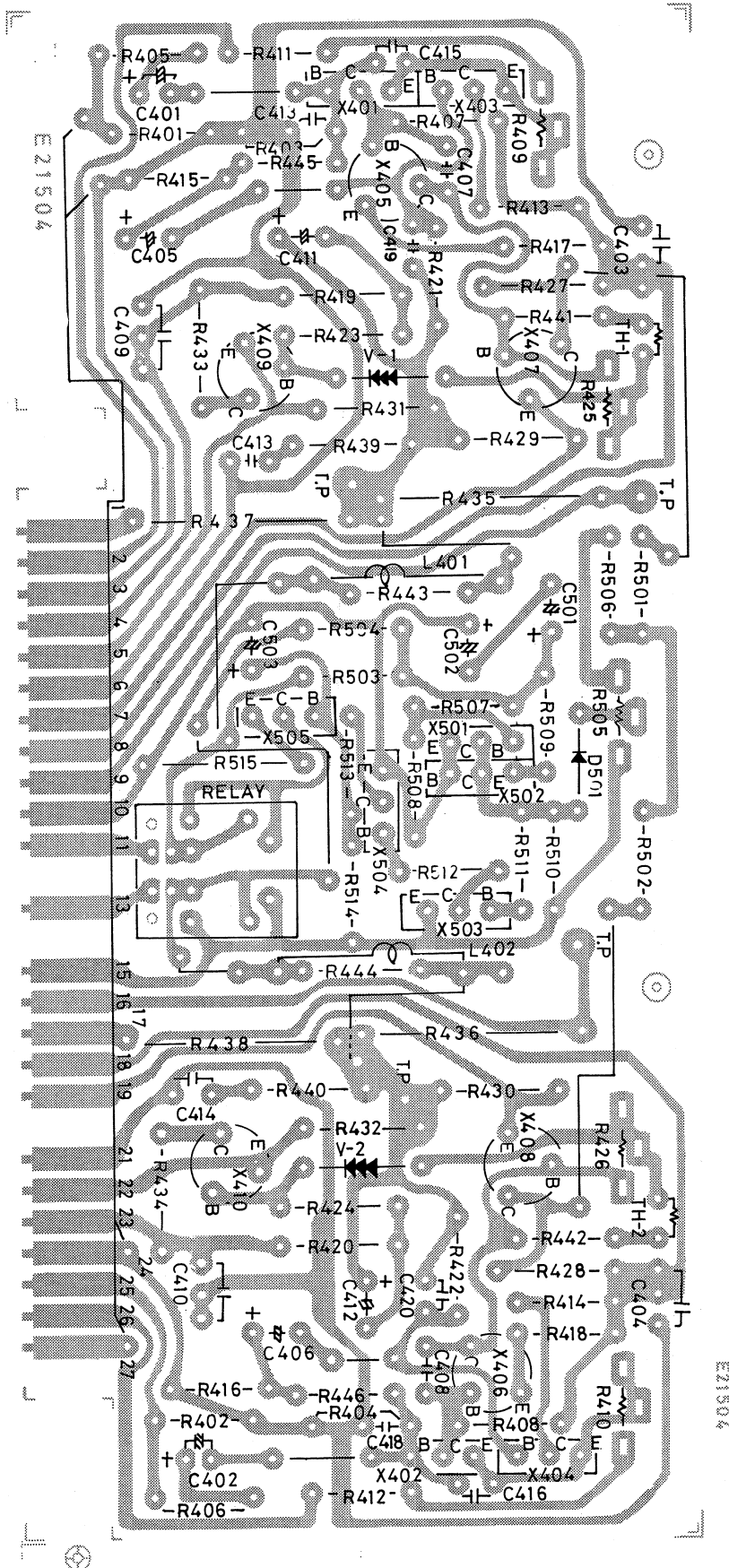

Fig. 16

TAC-229G S.E.A. CIRCUIT BOARD ASS'Y (TOP VIEW)

E21131

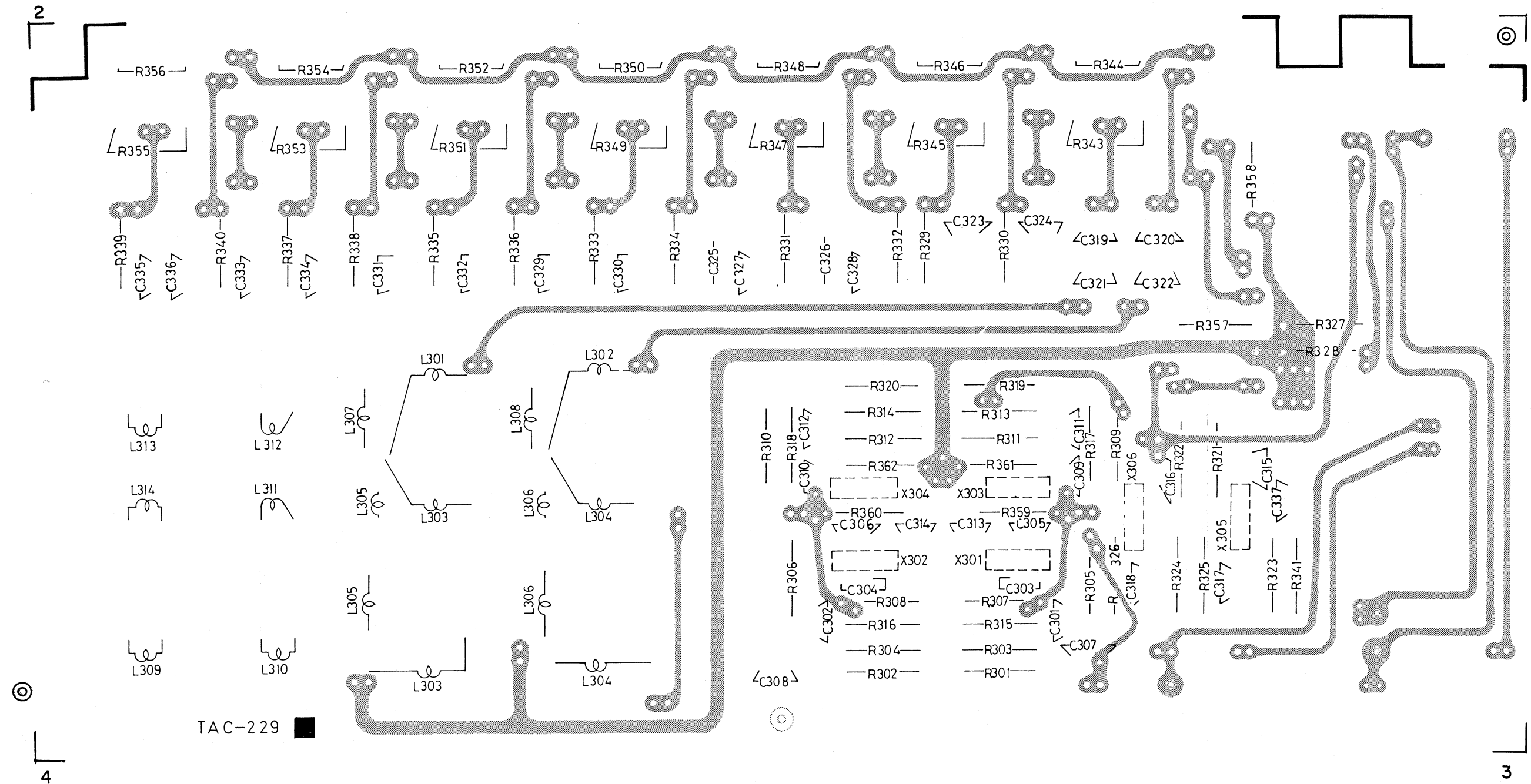

Fig. 17

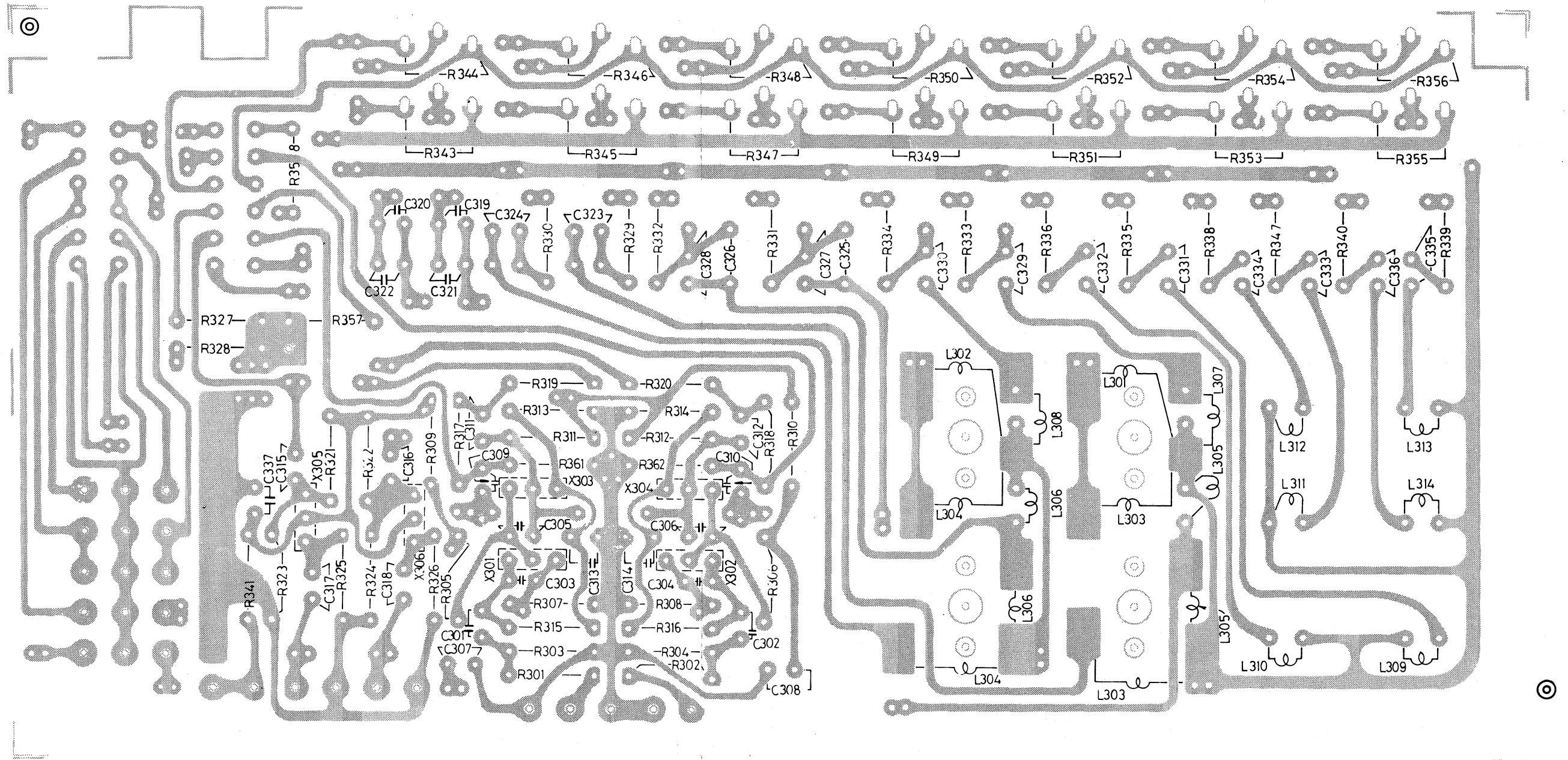

Fig. 18

TAC-295 PIN JACK CIRCUIT BOARD ASS'Y (BOTTOM VIEW)

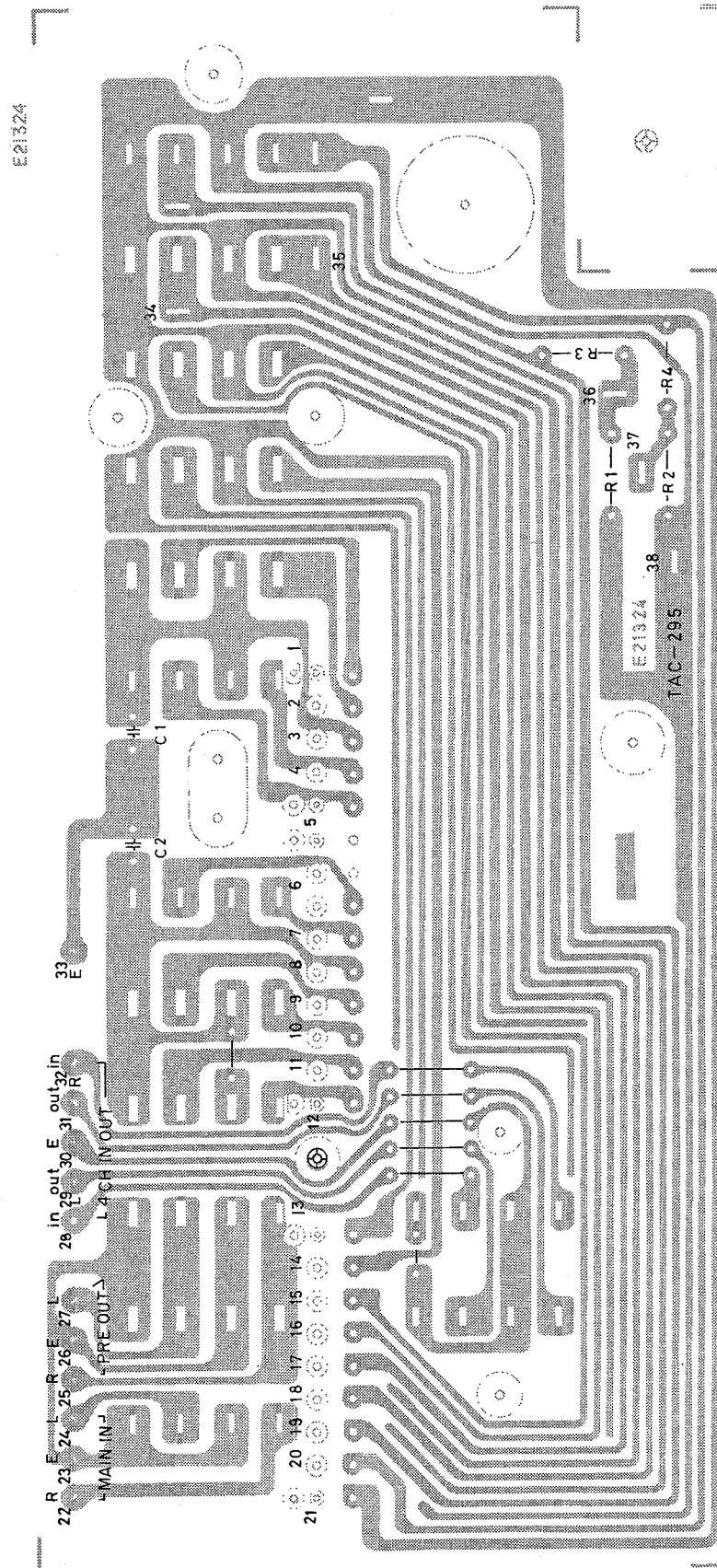

Fig. 19

THE LIST OF PARTS FOR REPLACEMENT ABOUT EACH CIRCUIT BOARD

TAP-199B POWER SUPPLY CIRCUIT BOARD (Fig. 12)

Symbol No.	Parts No.	Parts Name	Description
X701	2SC984B	Silicon Transistor	
D701	EASC02-03C	Silicon Diode (+)	
D702	ESAC02-03N	Silicon Diode (-)	
D703	FR2-02	Silicon Diode	
ZD701	E0771-14	Zenor Diode	
C701	QFZ0051-013	O.F.T. Capacitor	0.01 μ F Oil Filled Tublar
C702	QED22CA-107	E. Capacitor	100 μ F/160V Electrolytic
C703	QED22EA-336	E. Capacitor	33 μ F/100V
C704	QEW21JA-227	E. Capacitor	220 μ F/63V
C705	QCF12HP-103	Ceramic Capacitor	0.01 μ F
C706	QEW41HA-107	E. Capacitor	100 μ F/50V
R701	QRG021K-102	O.M.F. Resistor	1k Ω (2W) Oxide Metalized Film
R702	QRC121K-563	Comp. Resistor	56k Ω (1/2W)
R703	QRG011K-561	O.M.F. Resistor	560 Ω (1W)
R704	QRC121K-122	Comp. Resistor	1.2k (1/2W) Composition
R705	QRC121K-472	Comp. Resistor	4.7k (1/2W)
	E46687-001	Wrapping Bar	

TXX-2 (TAC-293, TAC-294) FILTER CIRCUIT BOARD AND VOLUME CIRCUIT BOARD (Fig. 13,14)

CAUTION : TXX-2 consists of TAC-293 and TAC-294. Two blocks of circuit are combined when manufacturing.
If you order TAC-293 or TAC-294, write the parts name as TXX-2.

Symbol No.	Parts No.	Parts Name	Description
S12~S13	QSP0220-002	Push Switch	2 keys 2 poles
VR3~VR6	QVN4A2B-5F5	V. Resistor	MASTER 250k(B) 4 Ganged
VR1~VR2	E03454-003	V. Resistor	BALANCE 250k(MN) Dual
C801,802	QFM41HK-154	Mylar Capacitor	0.15 μ F/50V
C803,804	QFM41HK-154	Mylar Capacitor	0.15 μ F/50V
C805,806	QFM41HK-472	Mylar Capacitor	0.0047 μ F/50V
R801,802	QRD141K-474	Carbon Resistor	470k (1/4W)
R803,804	QRD141K-334	Carbon Resistor	330k (1/4W)
R805,806	QRD141K-564	Carbon Resistor	560k (1/4W)
R807,808	QRD141K-222	Carbon Resistor	2.2k (1/4W)
R809,810	QRD141K-564	Carbon Resistor	560k (1/4W)
R811,812	QRD141K-563	Carbon Resistor	56k (1/4W)
C861,862	QFM41HK-103	Mylar Capacitor	0.01 μ F/50V
C863,864	QFM41HK-103	Mylar Capacitor	0.01 μ F/50V
R861,862	QRD141K-334	Carbon Resistor	330k (1/4W)
R863,864	QRD141K-334	Carbon Resistor	330k (1/4W)
R865,866	QRD141K-393	Carbon Resistor	39k (1/4W)
R867,868	QRD141K-393	Carbon Resistor	39k (1/4W)
R869,870	QRD141K-223	Carbon Resistor	22k (1/4W)
R871,872	QRD141K-223	Carbon Resistor	22k (1/4W)
	E43727-002	Tab	For wire wrapping

TAE-74 EQUALIZER CIRCUIT BOARD (Fig. 15)

Symbol No.	Parts No.	Parts Name	Description
	E33426-003	Switch Bracket	To fix the Switch & Circuit Board SELECT 4 poles 5 pos. 9PIN } (Plug for 7PIN } interconnection 5PIN } with Rear Panel) (Fiber board to prevent flux for Select Switch) For Wire wrapping
	QSR5545-200	Rotary Switch	
	E03564-9	Pin Plug Ass'y	
	E03564-7	Pin Plug Ass'y	
	E03564-5	Pin Plug Ass'y	
	E47331-001	Insulator	
	E43727-002	Wrapping bar	
X101,102	2SA493GR	Silicon Transistor	PNP Low Noise
X103,104	2SC1345DV	Silicon Transistor	NPN Low Noise
C101,102	QEZ0031-684	Tantalm Capacitor	0.68 μ F/25V
C103,104	QEW41EA-336	E. Capacitor	33 μ F/25V
C105,106	QCS11HJ-391	Ceramic Capacitor	390PF
C107,108	QEW41EA-336	E. Capacitor	33 μ F/25V
C109,110	QFM41HJ-103	Mylar Capacitor	0.01 μ F/50V \pm 5% Error
C111,112	QFM41HJ-392	Mylar Capacitor	0.0039 μ F/50V \pm 5% Error
C113,114	QFM41HJ-392	Mylar Capacitor	0.0039 μ F/50V \pm 5% Error
C115,116	QCS11HJ-471	Ceramic Capacitor	470PF
C117,118	QEW41AA-107	E. Capacitor	100 μ F/10V
C119,120	QEB41HM-335	L.L.C.E. Capacitor	3.3 μ F/50V Low Leakage Current
R101,102	QRZ0019-683	Carbon Resistor	68k Ω (1/4W) Low Noise
R103,104	QRZ0019-683	Carbon Resistor	68k Ω (1/4W) Low Noise
R105,106	QRZ0019-102	Carbon Resistor	1k Ω (1/4W) Low Noise
R107,108	QRZ0019-564	Carbon Resistor	560k Ω (1/4W) Low Noise
R109,110	QRZ0019-274	Carbon Resistor	270k Ω (1/4W) Low Noise
R111,112	QRZ0019-105	Carbon Resistor	1M Ω (1/4W) Low Noise
R113,114	QRZ0019-223	Carbon Resistor	22k Ω (1/4W) Low Noise
R115,116	QRZ0019-154	Carbon Resistor	150k Ω (1/4W) Low Noise
R117,118	QRZ0019-563	Carbon Resistor	56k Ω (1/4W) Low Noise
R119,120	QRZ0019-471	Carbon Resistor	470 Ω (1/4W) Low Noise
R121,122	QRZ0019-334	Carbon Resistor	330k Ω (1/4W) Low Noise
R123,124	QRZ0019-183	Carbon Resistor	18k Ω (1/4W) Low Noise
R125,126	QRD121K-562	Carbon Resistor	5.6k Ω (1/2W)
R127,128	QRZ0019-221	Carbon Resistor	220 Ω (1/4W) Low Noise
R129,130	QRZ0019-683	Carbon Resistor	68k Ω (1/4W) Low Noise
R131,132	QRZ0019-471	Carbon Resistor	470 Ω (1/4W) Low Noise
R133,134	QRZ0019-104	Carbon Resistor	100k Ω (1/4W) Low Noise

TAC-295 PIN JACK CIRCUIT BOARD (Fig. 19)

Symbol No.	Parts No.	Parts Name	Description
	E03043-122	Pin Jack	12P } Input and Output 4P } terminal 9P } (Socket for Interconnection) 7P } with Equalizer Circuit 5P }
	E03043-42	Pin Jack	
	E03565-9	Pin Socket Ass'y	
	E03565-7	Pin Socket Ass'y	
	E03565-5	Pin Socket Ass'y	
C1,2	QCF11HP-403	Ceramic Capacitor	TV Buzz bypass capacitor
	E46687-001	Wrapping Bar	

TAD-124 POWER DRIVE & PROTECTION CIRCUIT (Fig. 16)

Symbol No.	Parts No.	Parts Name	Description
R425,426	QVP2A0B-052	V. Resistor	500(B)
R409,410	QVP2A0B-014	V. Resistor	10k(B)
R505	QVP2A0B-014	V. Resistor	10k(B)
	LD203P or MTS-2	Relay	
X401,402	2SC1345DV	Silicon Transistor	
X403,404	2SC1345DV	Silicon Transistor	
X405,406	2SA606M or L	Silicon Transistor	PNP
X407,408	2SC959M or L	Silicon Transistor	NPN (X407,409 & X408,410)
X409,410	2SA606M or L	Silicon Transistor	PNP (are pair transistors)
V1,2	E03094-002	Varistor	
TH1,2	E04026-4	Therminstor	
X501,502	2SC711AE	Silicon Transistor	
X503	2SA628AE	Silicon Transistor	
X504	2SC711AE	Silicon Transistor	
X505	2SC1213AB or AC	Silicon Transistor	
D501	1S426	Germanium Diode	
L401,402	E04059-002	Choke Coil	
C401,402	QEB41EM-335	L.L.C.E. Capacitor	3.3 μ F/25V
C403,404	QEW41HA-106	E. Capacitor	10 μ F/50V
C405,406	QEW41HA-476	E. Capacitor	47 μ F/50V
C407,408	QCS11HJ-220	Ceramic Capacitor	22PF
C409,410	QEW41HA-106	E. Capacitor	10 μ F/50V
C411,412	QEW41HA-476	E. Capacitor	47 μ F/50V
C413,414	QFM41HK-473	Mylar Capacitor	0.047 μ F/50V
C415,416	QCS11HJ-391	Ceramic Capacitor	390PF
C501,502	QEW41CA-227	E. Capacitor	220 μ F/16V
C503	QEW41CA-107	E. Capacitor	100 μ F/25V
R401,402	QRD141K-474	Carbon Resistor	470k Ω (1/4W)
R403,404	QRD141K-683	Carbon Resistor	68k Ω (1/4W)
R405,406	QRD141K-332	Carbon Resistor	3.3k Ω (1/4W)
R407,408	QRD141K-332	Carbon Resistor	3.3k Ω (1/4W)
R411,412	QRD141K-222	Carbon Resistor	2.2k Ω (1/4W)
R413,414	QRD141K-332	Carbon Resistor	3.3k Ω (1/4W)
R415,416	QRD141K-102	Carbon Resistor	1k Ω (1/4W)
R417,418	QRD141K-100	Carbon Resistor	10 Ω (1/4W)
R419,420	QRD141K-152	Carbon Resistor	1.5k Ω (1/2W)
R421,422	QRD141K-223	Carbon Resistor	22k Ω (1/4W)
R423,424	QRD141K-392	Carbon Resistor	3.9k Ω (1/4W)
R427,428	QRC121K-220	Comp. Resistor	22 Ω (1/2W)
R429,430	QRC121K-221	Comp. Resistor	220 Ω (1/2W)
R431,432	QRC121K-221	Comp. Resistor	220 Ω (1/2W)
R433,434	QRC121K-220	Comp. Resistor	22 Ω (1/2W)
R435,436	QRF051K-R33	Unflamable Resistor	0.33 Ω (5W)
R437,438	QRF051K-R33	Unflamable Resistor	0.33 Ω (5W)
R439,440	QRC121K-100	Comp. Resistor	10 Ω (1/2W)
R441,442	QRD141K-560	Carbon Resistor	56 Ω (1/4W)
R501,502	QRD141K-122	Carbon Resistor	1.2k Ω (1/4W)
R503,504	QRD141K-103	Carbon Resistor	10k Ω (1/4W)

Symbol No.	Parts No.	Parts Name	Description
R506	QRC121K-103	Comp. Resistor	10k Ω (1/2W)
R507	QRD141K-103	Carbon Resistor	10k Ω (1/4W)
R508	QRD141K-392	Carbon Resistor	3.9k Ω (1/4W)
R509	QRD141K-333	Carbon Resistor	33k Ω (1/4W)
R510	QRD141K-222	Carbon Resistor	2.2k Ω (1/4W)
R511	QRD141K-471	Carbon Resistor	470 Ω (1/4W)
R512	QRD141K-473	Carbon Resistor	47k Ω (1/4W)
R513	QRD141K-560	Carbon Resistor	56 Ω (1/4W)
R514	QRD141K-104	Carbon Resistor	100k Ω (1/4W)
R515	QRG011K-331	O.M.F. Resistor	330 Ω 1W)

TAC-229G S.E.A. CONTROL CIRCUIT (Fig. 17, 18)

Symbol No.	Parts No.	Parts Name	Description
S9,10	E33085-001	Circuit Board Bracket	
	QSP0220-001	Push Switch	S.E.A. ON/OFF, S.E.A. REC 2key
	E47611-002	Push Switch Bracket	To fix the Bracket
	SBSB3006N	Tapping Screw	Wire Wrapping
L301,302,303 304	E03108-19A or B	Choke Coil	S.E.A. 40Hz 150Hz
	E0747-11	Ferri Inductor	S.E.A. 1kHz
L305,306	E0747-12	Ferri Inductor	S.E.A. 5kHz
L307,308	E0747-13	Ferri Inductor	S.E.A. 15kHz
L309,310	SPSP2604N	Screw	To fix choke coils
R343~352	QVD3A2W-754	V. Resistor	S.E.A. 50k Ω (W) Dual
X301,302,303 304	2SC458ALGC	Silicon Resistor	
C301,302	QEB41EM-335	L.L.C.E. Capacitor	3.3 μ F/25V
C303,304	QCS11HJ-471	Ceramic Capacitor	470PF
C305,306	QCS11HJ-220	Ceramic Capacitor	22PF
C307,308	QEW41HA-106	E. Capacitor	10 μ F/50V
C309,310	QEW40JA-336	E. Capacitor	33 μ F/6.3V
C311,312	QEW41HA-335	E. Capacitor	3.3 μ F/50V
C313,314	QEW41CA-336	E. Capacitor	33 μ F/16V
C319,320	QEB41EM-106	L.L.C.E. Capacitor	10 μ F/16V
C323,324	QEB41EM-684	L.L.C.E. Capacitor	0.68 μ F/25V
C327,328	QFM41HK-224	Mylar Capacitor	0.22 μ F/50V
C329,330	QFM41HK-473	Mylar Capacitor	0.047 μ F/50V
C331,332	QFM41HK-103	Mylar Capacitor	0.01 μ F/50V
C337	QEW41HA-106	E. Capacitor	10 μ F/50V
R301,302	QRZ0019-102	Carbon Resistor	1k Ω (1/4W)
R303,304	QRZ0019-564	Carbon Resistor	560k Ω (1/4W)
R305,306	QRZ0019-473	Carbon Resistor	47k Ω (1/4W)
R307,308	QRZ0019-472	Carbon Resistor	4.7k Ω (1/4W)
R309,310	QRZ0019-222	Carbon Resistor	2.2k Ω (1/4W)
R311,312	QRZ0019-472	Carbon Resistor	4.7k Ω (1/4W)
R313,314	QRZ0019-102	Carbon Resistor	1k Ω (1/4W)
R315,316	QRZ0019-104	Carbon Resistor	100k Ω (1/4W)
R317,318	QRZ0019-683	Carbon Resistor	68k Ω (1/4W)
R319,320	QRZ0019-392	Carbon Resistor	3.9k Ω (1/4W)
R327,328	QRZ0019-472	Carbon Resistor	4.7k Ω (1/4W)
R329,330	QRZ0019-471	Carbon Resistor	470 Ω (1/4W)
R331,332	QRZ0019-561	Carbon Resistor	560 Ω (1/4W)
R333,334,335 336	QRZ0019-681	Carbon Resistor	680 Ω (1/4W)
R341	QRC121K-561	Comp. Resistor	560 Ω (1/2W)
R357,358	QRZ0019-472	Carbon Resistor	4.7k Ω (1/4W)
R359,360	QRZ0019-154	Carbon Resistor	150k Ω (1/4W)

Comparison Table for Line Voltage, Power Consumption, Primary Fuse by Areas.

JA-S5	Line Voltage	Power Consumption
U.S.A.	AC 120V 50/60Hz	130W
CANADA	AC 120V 50/60Hz	150W
PACEX/NEX	AC 110V/220V 50/60Hz	90W
AUSTRALIA	AC 240V 50Hz	235W
OTHER AREAS	AC 100V/120V/220V/240V 50/60Hz	235W
SCANDINAVIA & SWITZERLAND	AC 220V 50Hz	235W

Parts List with Specified Numbers for Designated Areas.

Page	Dwg. No.	Original	Parts Name	For Europe	For Australia and U.K.	For Europe except SEMKO, SEV	For PACEX NEX and other countries except U.S.A. Canada Europe and Australia	For Canada
5		QMF61U1-3R0	Fuse	Not included	QMF60R1-2R3	QMF60R1-4R0	QMF60R1-4R0	Not included
		BT20002C	Warranty card	"	Not included	QMF60R1-2R3	QMF60R1-2R3	BT20008
		E30580-428A	Instruction book	E30580-429A	Same as original	Not included	BT20014	Same as original
7	16	QMF61U1-3R0	Fuse	QMF51A2-1R6	QMF60R1-2R3	QMF60R1-4R0	QMF60R1-4R0	Same as original
8 11 11	9	QSU1221-001	Power switch	QSY2220-004	QSY2220-004	QSL1135-007	QSL1135-007	Same as original
	10	E31704-001	Cord stopper	Same as original	E31704-002	Same as original	Same as original	"
	11	QMP1200-244	Power Cord	E03544-001 (SEMKO) QMP3800-240 (SEV)	E03551-002	"	"	"
11	15	QMC0234-001	AC socket	Not included	Not included	"	"	"
		Not included	Cover	Not included	Not included	E46603-001	E46603-001	Not included
			Voltage select socket	"	"	QMC9004-001	QMC9004-001	"
			Voltage select plug	"	"	QMC9005-001	QMC9005-001	"
			Plate (to be replaced for AC socket)	E48140-002	E48140-002	Not included	Not included	"

JVC AMERICA, INC.

50-35, 56th Road, Maspeth

New York, N.Y. 11378

Manufactured by

Victor Company of Japan, Limited

MODEL JA-S5 SCHEMATIC

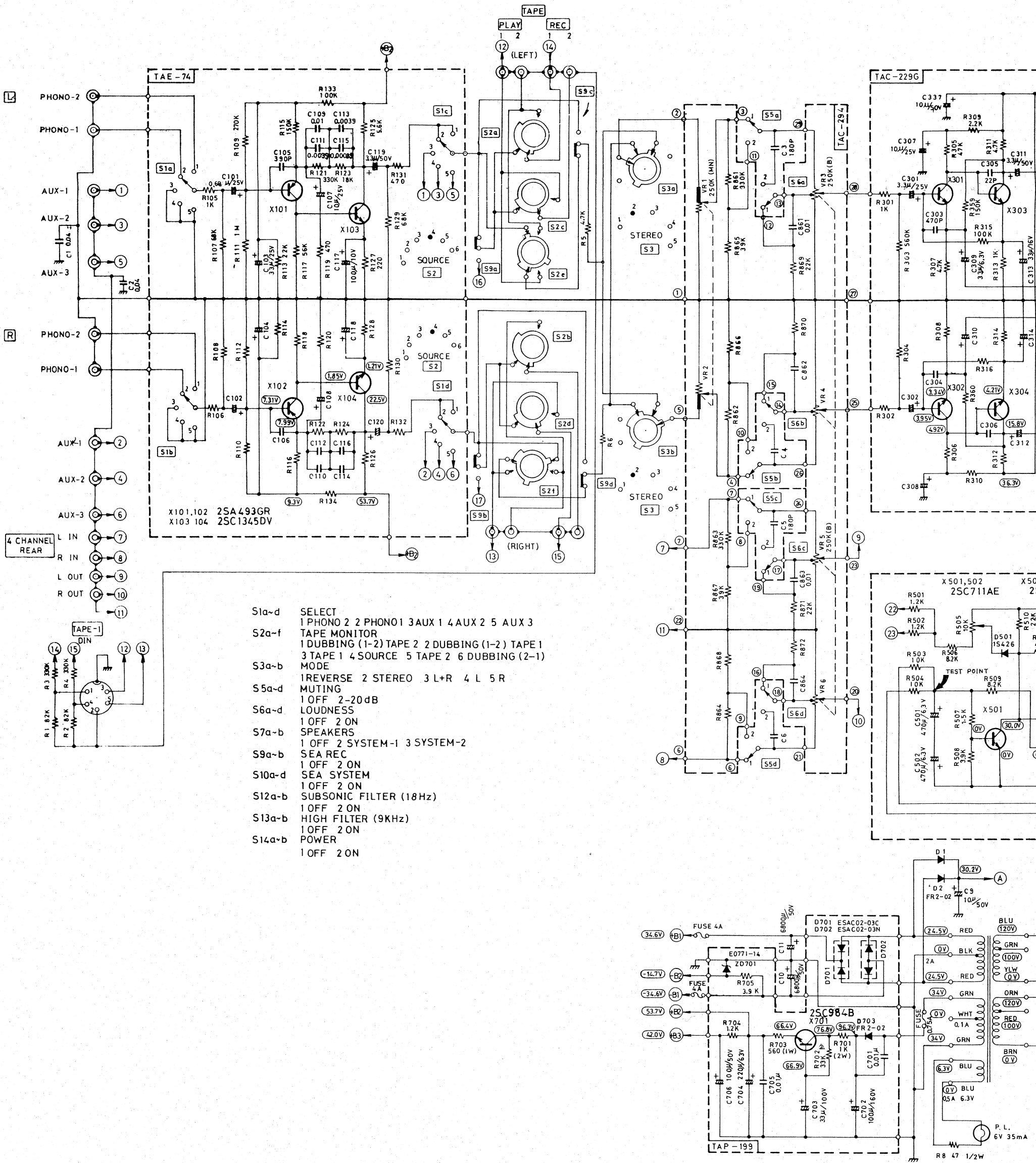

- S1a-d SELECT
1 PHONO 2 2 PHONO1 3 AUX 1 4 AUX 2 5 AUX 3
- S2a-f TAPE MONITOR
1 DUBBING (1-2) TAPE 2 2 DUBBING (1-2) TAPE 1
3 TAPE 1 4 SOURCE 5 TAPE 2 6 DUBBING (2-1)
- S3a-b MODE
1 REVERSE 2 STEREO 3 L+R 4 L 5 R
- S5a-d MUTING
1 OFF 2-20dB
- S6a-d LOUDNESS
1 OFF 2 ON
- S7a-b SPEAKERS
1 OFF 2 SYSTEM-1 3 SYSTEM-2
- S9a-b SEA REC
1 OFF 2 ON
- S10a-d SEA SYSTEM
1 OFF 2 ON
- S12a-b SUBSONIC FILTER (18Hz)
1 OFF 2 ON
- S13a-b HIGH FILTER (9KHz)
1 OFF 2 ON
- S14a-b POWER
1 OFF 2 ON

X101,102 2SA493GR
X103,104 2SC1345DV

X501,502 2SC711AE

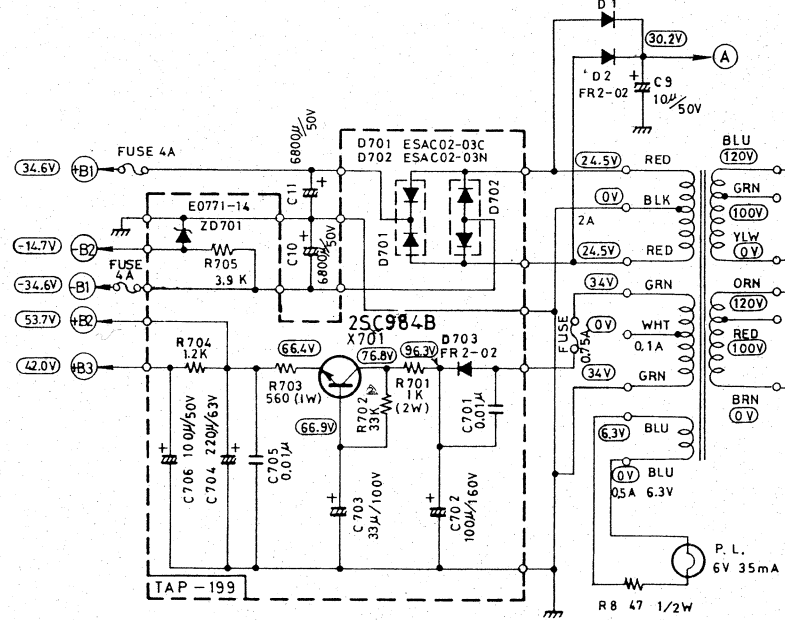

5 SCHEMATIC DIAGRAM

* This Schematic Diagram is for U.S.A.

Note : The primary circuit and parts of the other circuits are slightly different from this diagram in other areas, therefore please see the schematic diagrams shown on the back page.

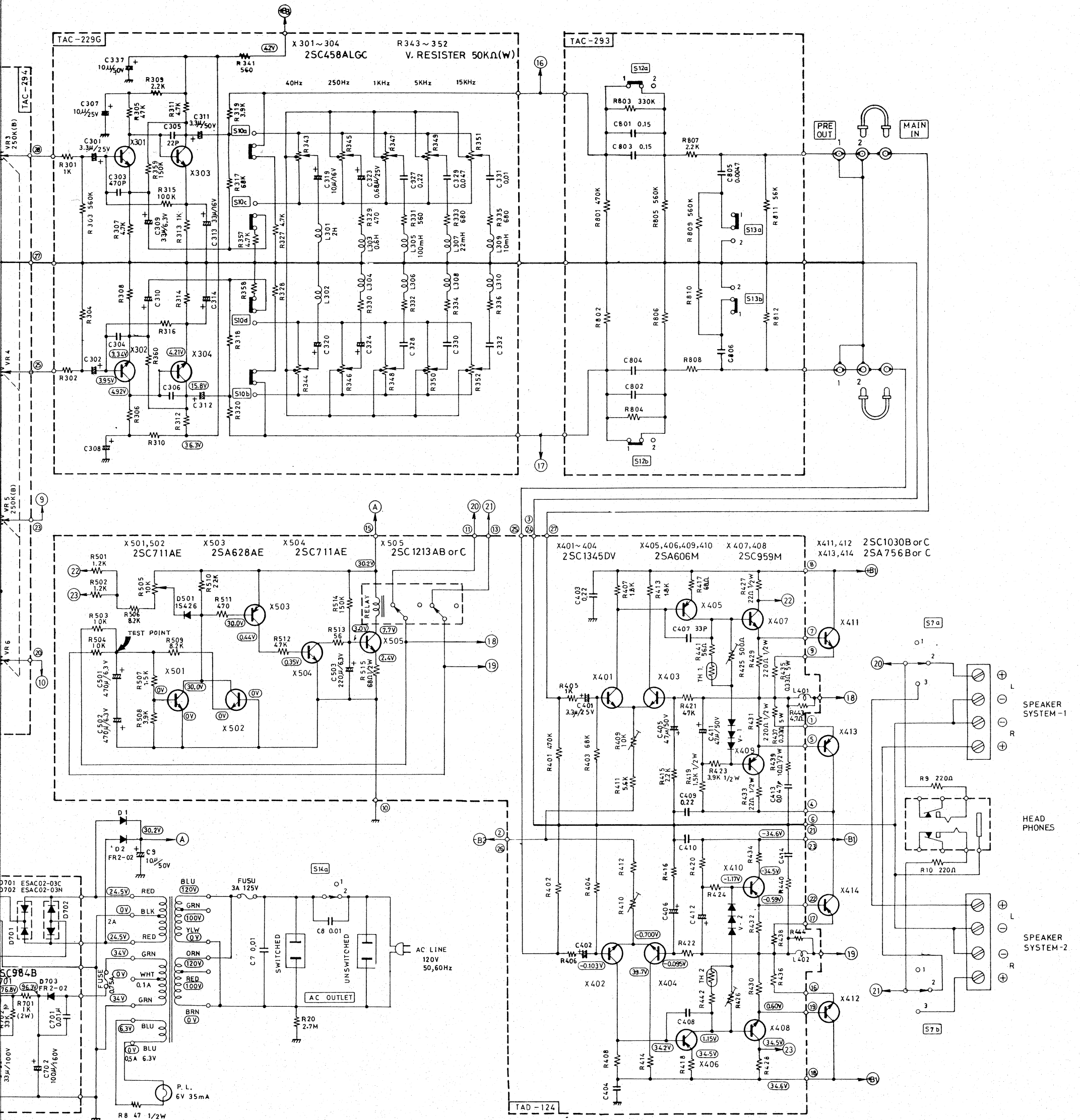

Subject to change without notice.

Printed in Japan E30539-417A,(O)

[E] FOR EUROPE

■ PRIMARY CIRCUIT (220V 50Hz ~)

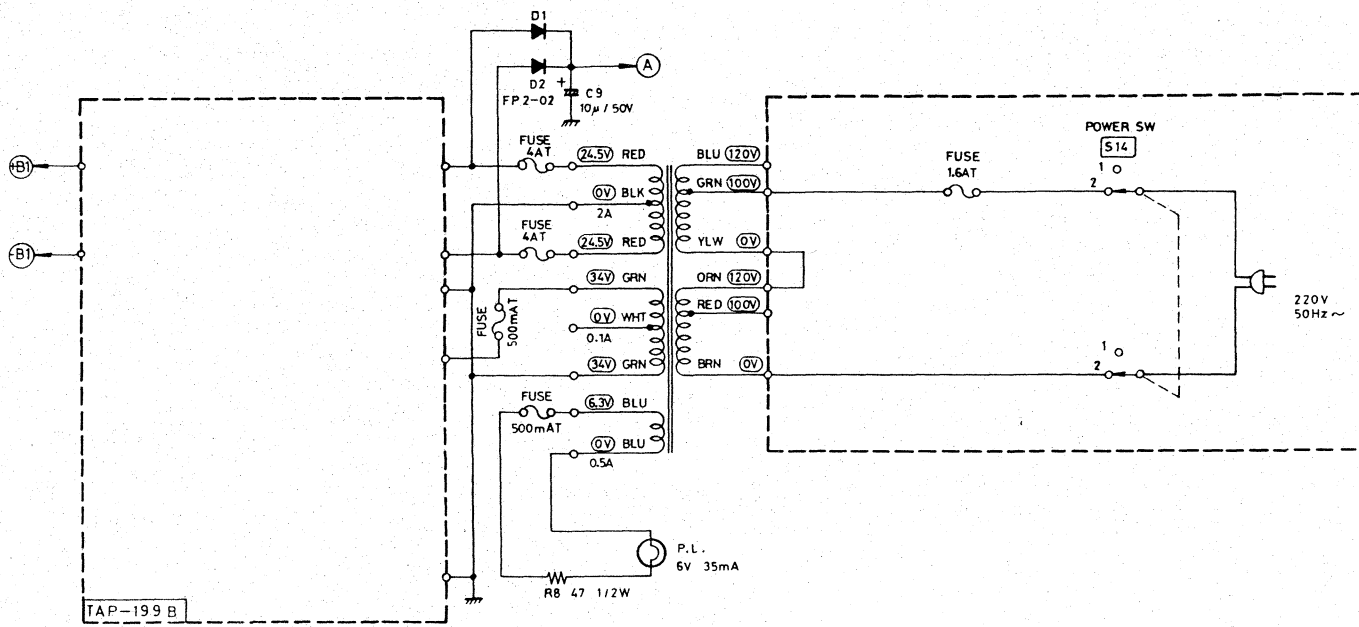

TAP-199 B

[M]

TAP

[F] FOR EUROPE

■ PRIMARY CIRCUIT (AC 100, 120, 220, 240V 50 / 60 Hz)

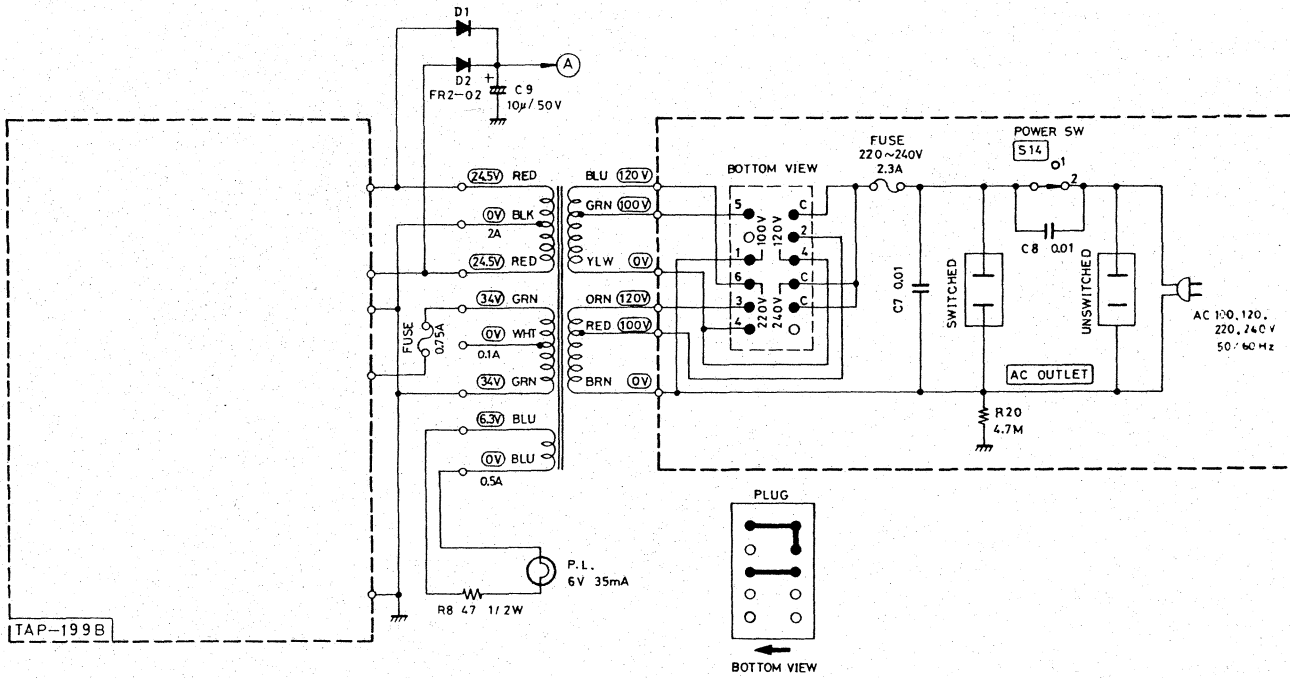

TAP-199 B

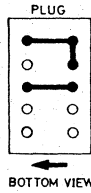

[P]

TAP

[A] FOR AUSTRALIA AND U.K

■ PRIMARY CIRCUIT (240V 50Hz ~)

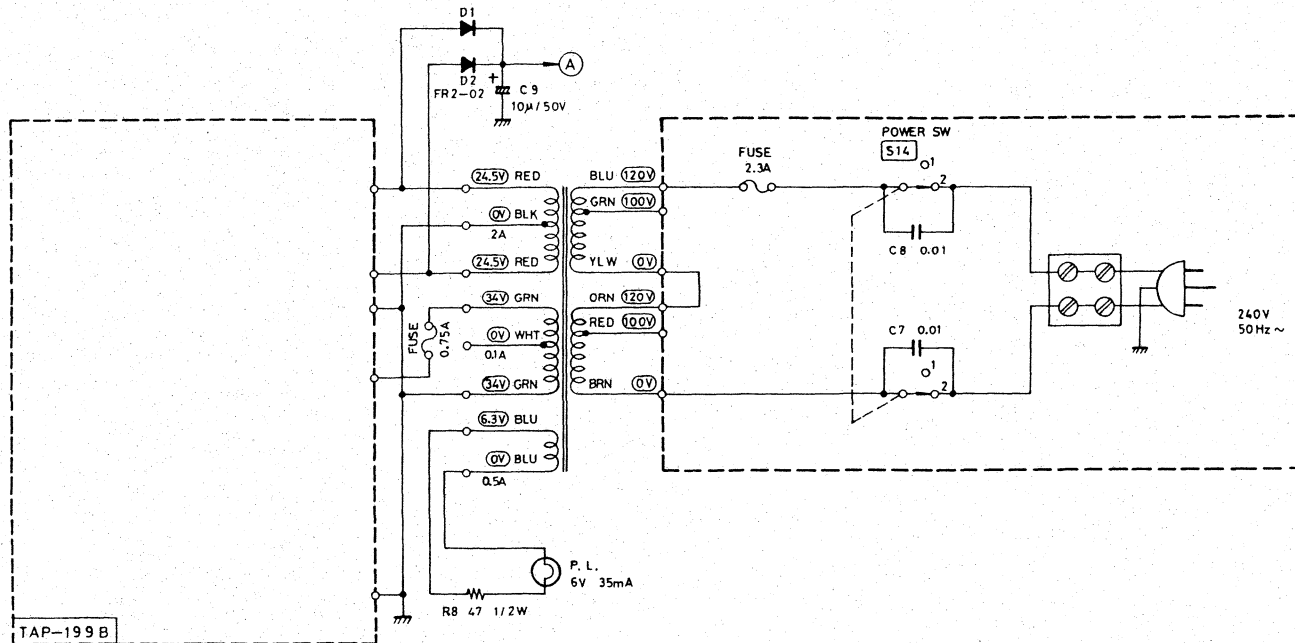

TAP-199 B

[M] FOR CANADA

■ PRIMARY CIRCUIT (AC 120V 50/60Hz)

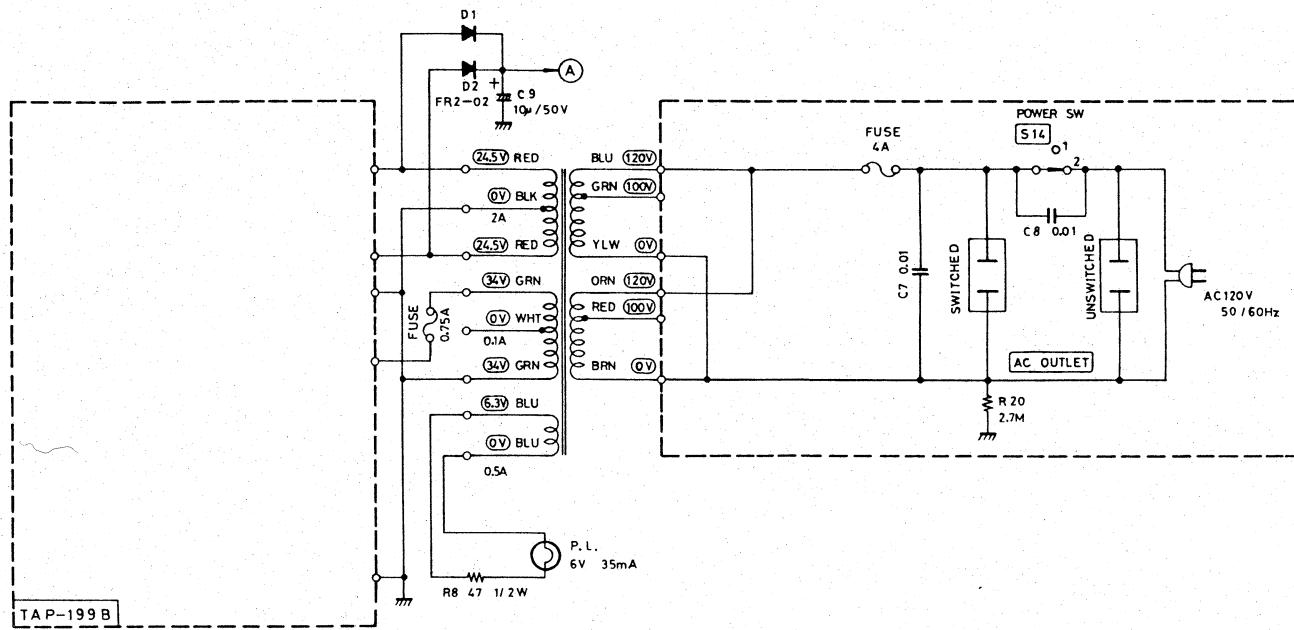

[P][U] FOR PACEX NEX AND OTHER COUNTRIES

■ PRIMARY CIRCUIT (AC 100,120, 220, 240V 50/60Hz)

